



AIR LOGISTICS CORPORATION

MAIN OFFICE: 146 RAILROAD AVENUE MONROVIA CA 91016
626.256.1257 FAX: 626.359.1689
FACS OFFICE: 925 N. TODD AVENUE AZUSA CA 91702
626.633.0294 FAX: 626.633.0791

ROLLER ADAPTER PRODUCTS AND SPECIFICATIONS



MODEL 2550 SINGLE ROLLER
ADAPTER-P/N 104568*
NSN 1730-00-986-3702*



MODEL 2620 DOUBLE ROLLER ADAPTER-
P/N 105612* (MODEL 2610-P/N 105710*
WITHOUT UPLOAD ADAPTER)

***ALTERNATE COLORS AVAILABLE ON REQUEST**

Model 2550 Single Roller Adapter Specifications

Working Capacity Lbs. (Kg)

Down: 5,500 (2,495) Up: 650 (295) Side: 650 (295) Braking: 7,000 (3,175)

Dimensions Inches (Cm):

A: 3.38 (8.59) B: 10.50 (26.67) C: 4.375 (11.11) D: 5.25 (13.34)
E: 4.61 (11.71) F: 3.25 (8.26) G: 4.53 (11.51)

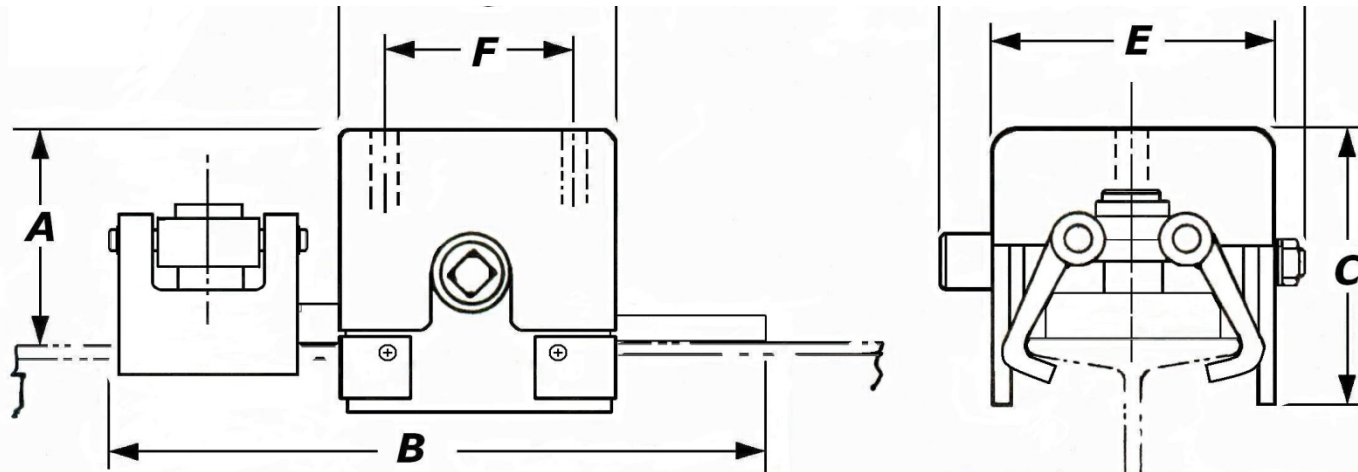

Model 2610/2620 Dual Roller Adapter Specifications

Model 2610: 1730-01-312-6150 (Yellow)

Model 2610: 1680-01-554-2003 (Dark Blue-Green)

Model 2620: NSN 1730-01-312-6170 (Yellow)

Note: Upload Roller is recommended if the payload CG is off-center between fore and aft roller adapters or is high above the rails.

Working Capacity Lbs. (Kg)

Down: 7,500 (3,402) Up: 650 (295) Side: 1,000 (454) Braking: 7,000 (3,175)

Dimensions In. (Cm):

A: 3.38 (8.59) B: 12.50 (31.75) C: 4.375 (11.11) (5.25 (13.34) for 2620)

D: 6.96 (17.68) (8.15(20.70) for 2620) E: 4.52 (11.48) F: 5.00 (12.70)

G: 6.90 (17.53)

